



CE Report  
EN62368-1

UK  
BS EN62368-1

RoHS

## FEATURES

- Universal 3x320-550VAC or 450-800VDC Input voltage three-phase input (two or three phase are available)
- Input withstand 3x600VAC/5s
- Active PFC, PF up to 0.95
- Operating ambient temperature range: -40°C to +70°C (50°C full load)
- Standard DIN-Rail mounting
- High efficiency, high reliability
- LED indicator for output status
- 150% peak power lasts for 3s
- Output short circuit, over-current, over-voltage, over-temperature protection
- DC OK function
- Double-sided conformal coating
- Operating altitude up to 5000m
- OVC III, 2000m altitude (design refer to EN61010)
- Design refer to UL508, UL/IEC62368

LITF480-26BxxS Series is Mornsun AC-DC three-phase Din-Rail switching power supply. It features cost-effective, high efficiency and high reliability. With 150% power reserve, enough to support starting DC motor or capacitive load and other heavy load. These converters offer excellent EMC performance and design refer to UL508, UL/IEC62368, EN62477, IEC60664 standards and they are widely used in areas of industrial control equipment, factory automation and mechanical and electrical equipment and other industrial control fields.

## Selection Guide

Certification	Part No.	Output Power (W)	Nominal Output Voltage and Current (Vo/Io)	Output Voltage Adjustable Range ADJ (V)*	Efficiency at 400VAC (%) Typ.	Max. Capacitive Load (µF)
EN	LITF480-26B24S	480	24V/20A	24-28	94	20000
	LITF480-26B48S		48V/10A	48-55	95	10000

Note: \*The actual adjustment range may extend outside the values stated, care should be exercised to ensure that the output voltage and power levels remain within the published maximum values.

## Input Specifications

Item	Operating Conditions		Min.	Typ.	Max.	Unit
Input Voltage Range	Rated input (Certified voltage)		380	--	480	VAC
	AC input		320	--	550	
	DC input		450	--	800	VDC
Input Voltage Frequency			47	--	63	Hz
Input Current	400VAC		--	--	0.85	A
	500VAC		--	--	0.7	
Inrush Current	400VAC	Cold start	--	50	--	
Power Factor	400VAC	Normal temperature, rated load	0.93	0.95	--	--
	500VAC		0.92	0.95	--	
Start-up Delay Time			--	0.8	--	s
Input Temporary Over-voltage	Rated load output, 600VAC input		5s/time, interval 10s, product without damaging			
Hot Plug			Unavailable			

### Output Specifications

Item	Operating Conditions	Min.	Typ.	Max.	Unit
Output Voltage Accuracy	Full load range	--	±1	--	%
Line Regulation	Rated load	--	±0.5	--	
Load Regulation	0% - 100% load	--	±1	--	
Ripple & Noise*	20MHz bandwidth (peak-to-peak value)	--	--	150	mV
Temperature Coefficient	0°C to +50°C	--	±0.03	--	%/°C
Minimum Load		0	--	--	%
Dynamic Minimum Load		10	--	--	%
Stand-by Power Consumption	400VAC	--	3.5	--	W
Hold-up Time	400VAC/500VAC	--	20	--	ms
150% peak load power		Continuous work 3s			
Short Circuit Protection		Enter hiccup mode after constant current operation for 3s (typ.), continuous, self-recovery			
Over-current Protection		≥ 130% I <sub>o</sub> , enter hiccup mode after constant current operation for 3s (typ.), self-recovery			
Over-voltage Protection	24V	≤ 33VDC	Hiccup, self-recovery		
	48V	≤ 63VDC			
Over-temperature Protection	Over-temperature Protection start	--	--	80	°C
	Over-temperature Protection release	55	--	--	

Note: 1.\*The "Tip and barrel method" is used for ripple and noise test, output parallel 47uF electrolytic capacitor and 0.1uF ceramic capacitor, please refer to Enclosed Switching Power Supply Application Notes for specific information;  
2.\*Full input voltage at room temperature, <5% I<sub>o</sub> range, 300mv (Max.).

### General Specifications

Item	Operating Conditions	Min.	Typ.	Max.	Unit		
Isolation	Input - output	4000	--	--	VAC		
	Input - ⊕	2000	--	--			
	Output - ⊕	500	--	--			
	Output - DC OK	500	--	--			
Insulation Resistance	Input - output	100	--	--	MΩ		
	Input - ⊕						
	Output - ⊕						
	Output - DC OK						
Operating Temperature		-40	--	70	°C		
Storage Temperature		-40	--	85	°C		
Operating Humidity	Non-condensing	--	--	95	%RH		
Storage Humidity		--	--	95			
Output Power Derating	Operating temperature derating	-40°C to -30°C	5.0	--	--	% / °C	
		+50°C to +70°C	2.5	--	--		
	Input voltage derating	320 - 340VAC	Three-phase input	1.0	--	--	% / VAC
		320 - 380VAC	Two-phase input (80% I <sub>o</sub> )	0.25	--	--	
Leakage Current	480VAC	< 0.5mA RMS					
Safety Standard		EN62368-1, BS EN62368-1 (Report); Design refer to UL61010-1, UL61010-2-201, UL508 & UL/IEC62368-1, EN62477, IEC60664					
Safety Class		CLASS I, ANSI/ISA71.04-2013					
MTBF	MIL-HDBK-217F@25°C	≥ 300,000 h					

### Environmental Characteristics

Item	Operating Conditions	Standard
Sinusoidal Vibration	10 - 500Hz, 2g, three directions of X, Y, Z axis	GB2423.10, IEC60068-2-6

### Mechanical Specifications

Case Material	Metal (AL5052, SPCC)
Dimensions	80.00 x 124.00 x 127.00mm
Weight	1080g (Typ.)
Cooling Method	Free air convection

### Electromagnetic Compatibility (EMC)

Emissions	CE	CISPR32/EN55032	CLASS B	
	RE	CISPR32/EN55032	CLASS B	
	Harmonic current	IEC/EN 61000-3-2	CLASS A	
	Voltage flicker	IEC/EN 61000-3-3	Fulfilled	
Immunity	ESD	IEC/EN 61000-4-2	Contact $\pm 8KV$ /Air $\pm 15KV$	Perf. Criteria A
	RS	IEC/EN 61000-4-3	10V/m	Perf. Criteria A
	EFT (input port)	IEC/EN 61000-4-4	$\pm 4KV$	Perf. Criteria A
	EFT (output port)	IEC/EN 61000-4-4	$\pm 2KV$	Perf. Criteria A
	EFT (DC OK port)	IEC/EN 61000-4-4	$\pm 1KV$	Perf. Criteria A
	Surge (input port)	IEC/EN 61000-4-5	Line to line $\pm 2KV$ /line to PE $\pm 4KV$	Perf. Criteria A
	Surge (output port)	IEC/EN 61000-4-5	Vo+ to Vo- $\pm 500V$ ; Vo+/Vo- to PE $\pm 1KV$	Perf. Criteria A
	Surge (DC OK port)	IEC/EN 61000-4-5	DC OK to PE $\pm 1KV$	Perf. Criteria A
	CS	IEC/EN 61000-4-6	10Vr.m.s	Perf. Criteria A
	PFMF	IEC/EN 61000-4-8	30A/m	Perf. Criteria A
	Voltage variations*	IEC61000-6-2/IEC61000-4-11	70% $U_n$ , 25/30 cycle(50/60Hz); 40% $U_n$ , 10/12 cycle(50/60Hz); 0% $U_n$ , 1 cycle	Perf. Criteria B
	Short interruptions*	IEC61000-6-2/IEC61000-4-11	0% $U_n$ , 250/300 cycle(50/60Hz)	Perf. Criteria C

Note: \*Both the two-phase and three-phase systems meet the requirements. The derating of the two-phase system must reach 80%,  $U_n$  Maximum input nominal voltage.

### Product Characteristic Curve

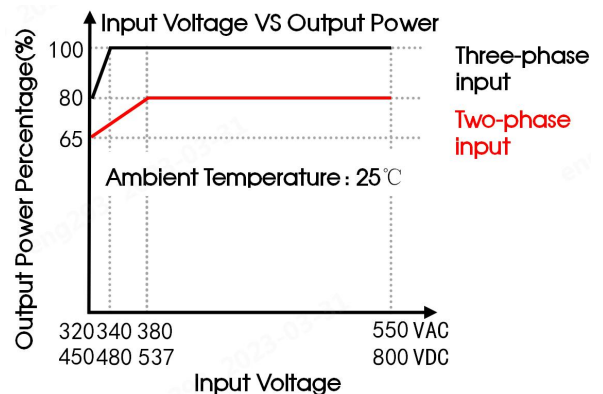
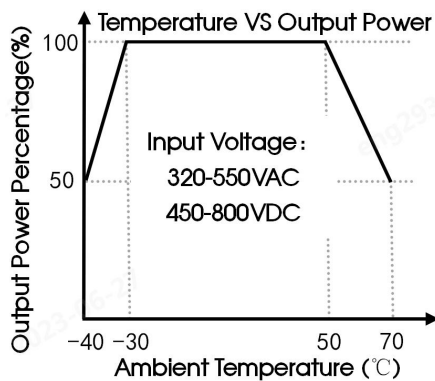

Over-current protection curve (Typ.)

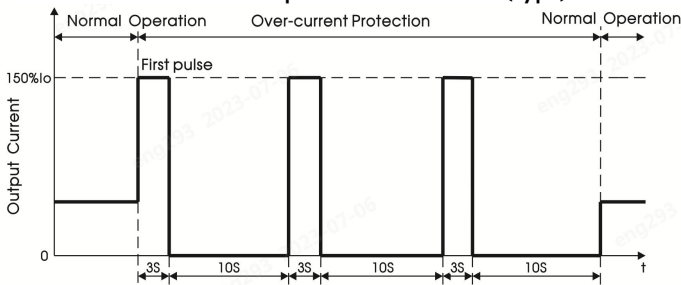

Short circuit protection curve (Typ.)

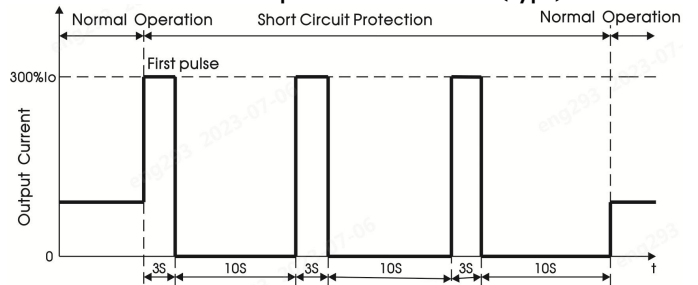

Note: 1. With an AC input voltage between 320 - 380VAC/450 - 537VDC the output power must be derated as per the temperature derating curves;  
 2. This product is suitable for applications using natural air cooling; for applications in closed environment please consult Mornsun's FAE.

Efficiency Vs Input Voltage (Full Load)

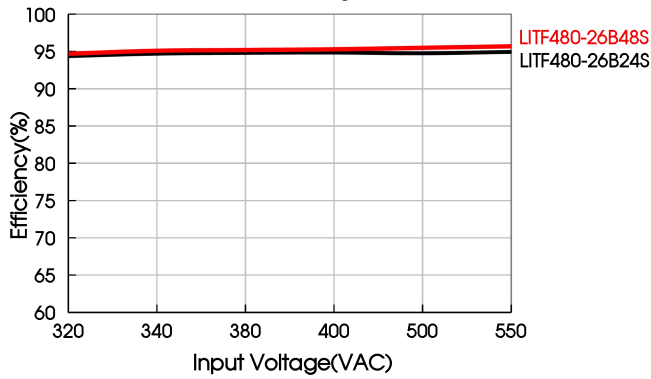

Efficiency Vs Output Load (Vin=400VAC)

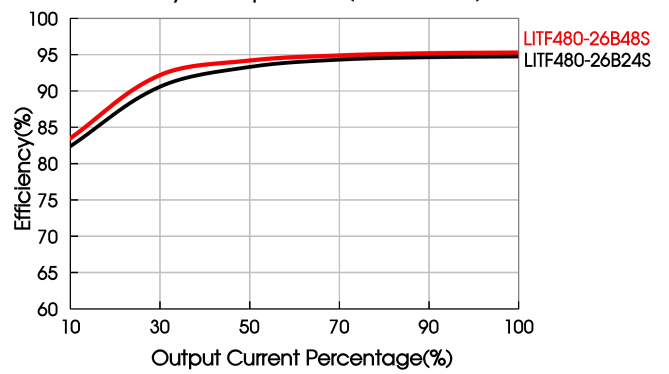

## Installation Diagram

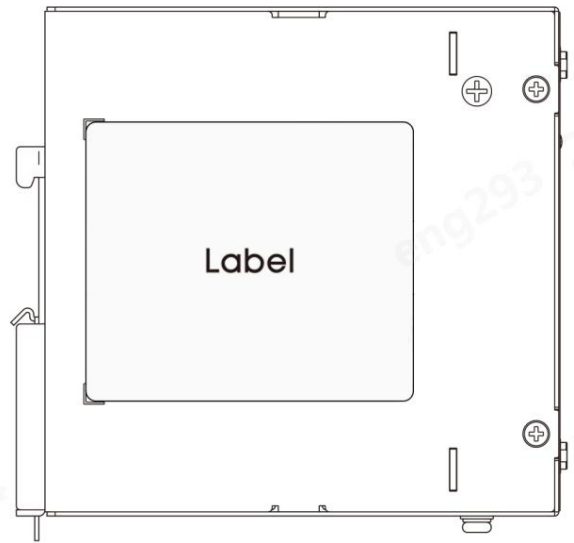
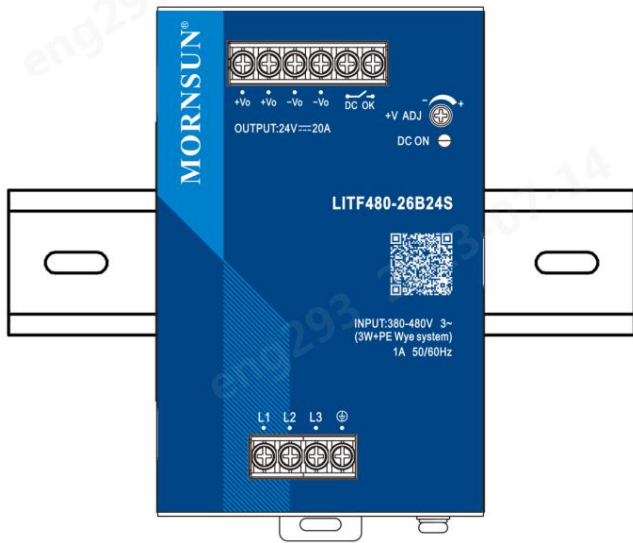

Materials required in the installation		
1	Product	1 PCS
2	Phillips screwdriver Slotted screwdriver	1 PCS
3	TS35/7.5 or TS35/15	1 PCS
4	24-10AWG Wire	/ PCS
	The content is for reference only. Regarding the actual wire diameter and tightening torque, refer to the dimensional drawing.	



Product

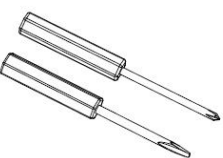

Phillips screwdriver  
Slotted screwdriver  
Diameter of the cutting  
Diameter: 3mm

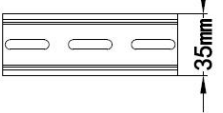

TS35/7.5 or TS35/15

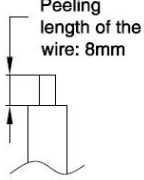

24-10AWG Wire

Peeling length of the wire: 8mm

### Installation Steps ①-②

① Clamp the buckle of the product into the TS35 DIN rail;

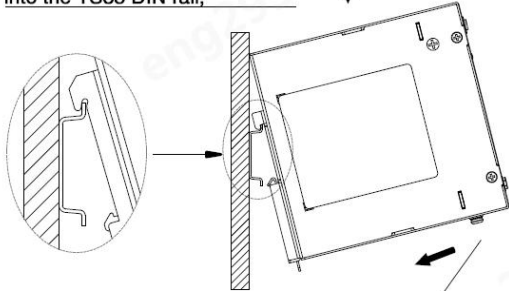

② Push the product vertically towards the TS35 DIN rail until hearing the sound of the buckle snapping into it.

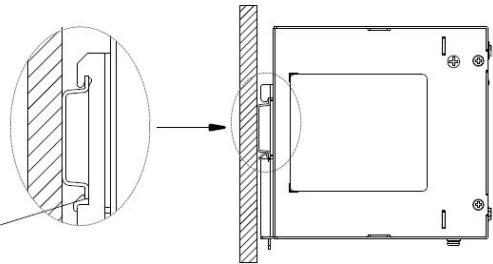

### Disassembly Steps ③-④

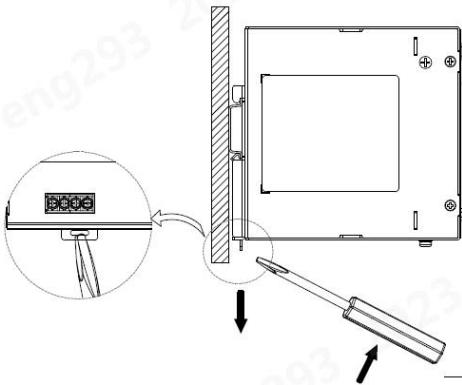

③ After inserting the Slotted screwdriver into the square groove at the bottom of the buckle, push the slider of the buckle downward in the direction shown in the figure.

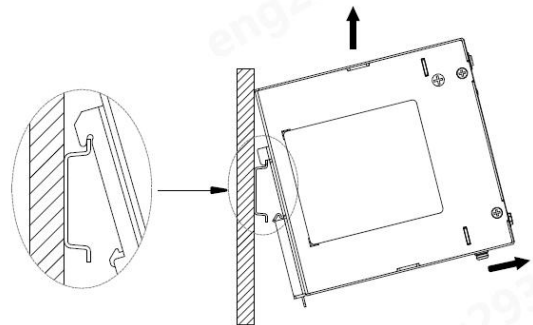

④ Hold the bottom of the product and push it outwards, then lift the product up to take the product out of the DIN rail.

### Wiring / Unwiring Steps ⑤-⑥

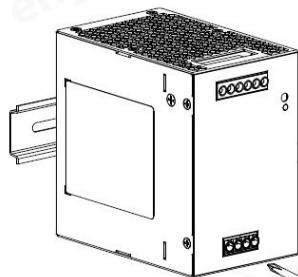

⑤ Use the Phillips screwdriver to loosen the terminal screws, insert the head of the wire into the bottom of the terminal, and then turn the screwdriver to tighten the terminal screws.

Tightening torque:  
Max0.5 N · m(For reference);

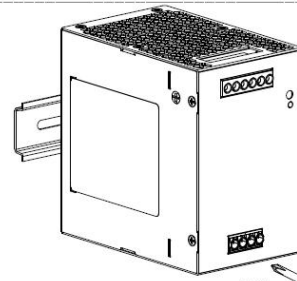

⑥ The Phillips screwdriver to loosen the terminal screws and pull the wires out of the terminal holes

Note: Keep the following installation clearances: 20mm on the top, 20mm on the bottom, 5mm on the left and right sides are recommended when the device is loaded permanently with more than 50% of the rated power. Increase this clearance to 15mm in case the adjacent device is a heat source (e.g. another power supply).

Dimensions and Recommended Layout

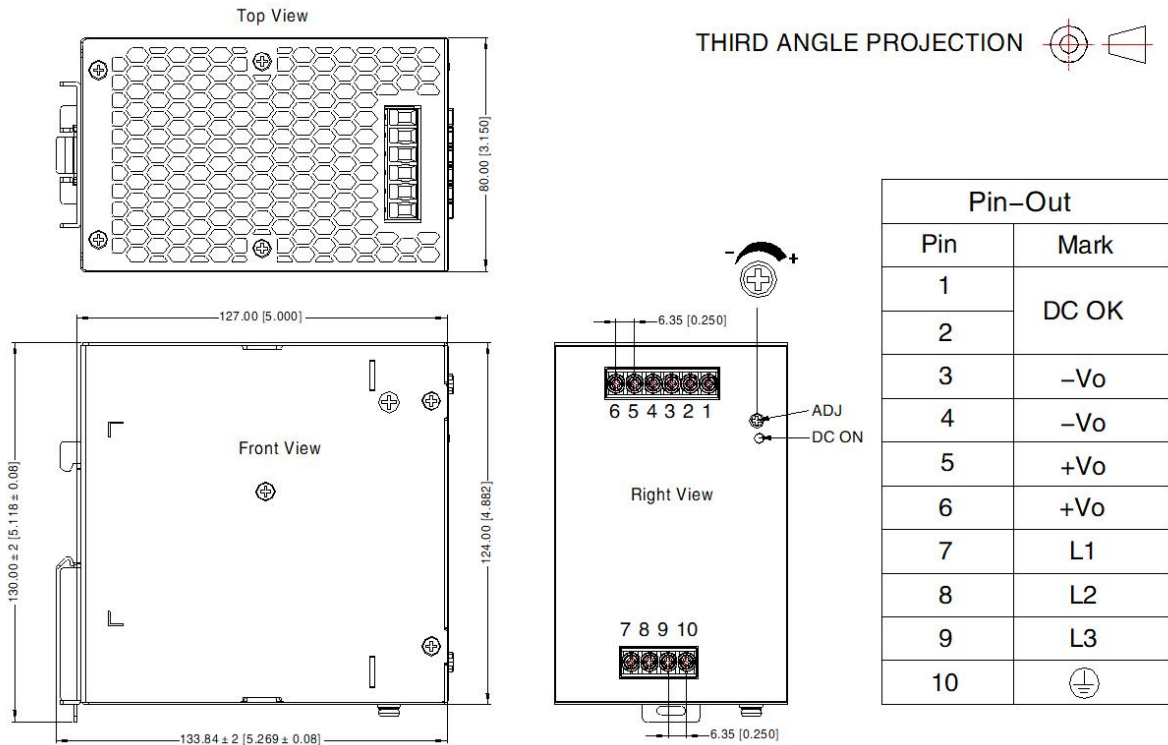

10, 11 any position must be connected to the earth ( ⊕ )

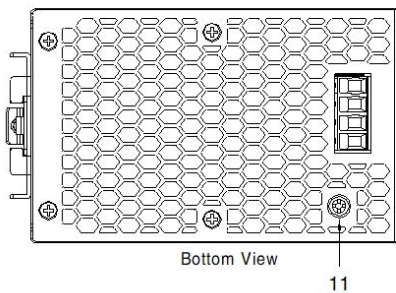

Note:

- Unit: mm[inch]
- DC ON: Output status indicator LED
- ADJ: Output adjustable resistor
- Wire range: Input: 26-10AWG(12-10AWG for pin10)
- Output: 24V: 10AWG
- 48V: 14-10AWG
- Tightening torque: Max 0.5N · m
- Mounting rail: TS35, rail needs to connect safety ground
- General tolerances: ± 1.00[ ± 0.039]



**WARNING** Risk of electrical shock, fire, personal injury or death:

**AVERTISSEMENT** AVERTISSEMENT Risque de choc électrique, d'incendie, de blessures corporelles ou de décès :

1. Do not use the power supply without proper grounding (Protective Earth). Use the terminal on the input block for earth connection and not one of the screws on the housing;  
N'utilisez pas l'alimentation électrique sans mise à la terre appropriée (Terre protectrice). Utilisez le terminal sur le bloc d'entrée pour la connexion terrestre et non pas une des vis sur le boîtier;
2. Turn power off before working on the device, protect against inadvertent re-powering;  
Éteignez l'alimentation avant de travailler sur l'appareil, protégez-vous contre la réenergisation accidentelle;
3. Make sure that the wiring is correct by following all local and national codes;  
Assurez-vous que le câblage est correct en suivant tous les codes locaux et nationaux;
4. Do not modify or repair the unit;  
Ne modifiez pas ou ne réparez pas l'appareil;
5. Do not open the unit as high voltages are present inside;  
Ne modifiez pas ou ne réparez pas l'appareil;
6. Use caution to prevent any foreign objects from entering the housing;  
Faire preuve de prudence pour empêcher les objets étrangers d'entrer dans le logement;
7. Do not use in wet locations or in areas where moisture or condensation can be expected;  
Faire preuve de prudence pour empêcher les objets étrangers d'entrer dans le logement;
8. Do not touch during power-on, and immediately after power-off, hot surfaces may cause burns;   
Ne touchez pas pendant l'alimentation et, immédiatement après l'alimentation, les surfaces chaudes peuvent causer des brûlures.
9. For ambient temperature  $\leq 60^{\circ}\text{C}$ , use  $\geq 90^{\circ}\text{C}$  - copper wire only; for ambient temperature  $>60^{\circ}\text{C}$  to  $85^{\circ}\text{C}$ , use  $\geq 105^{\circ}\text{C}$  - copper wire only; use only wires with a minimum dielectric strength of 300V (input) and 60V (output);  
Température ambiante  $\leq 60^{\circ}\text{C}$ , utiliser  $\geq 90^{\circ}\text{C}$  - seulement fils de cuivre; Température ambiante  $>60^{\circ}\text{C}$  et  $85^{\circ}\text{C}$ , utiliser  $\geq 105^{\circ}\text{C}$  - seulement fils de cuivre; Uniquement pour l'utilisation de fils de cuivre d'une résistance d'isolation minimale de 300V (d'entrée) et 60V (de sortie).

Note:

1. For additional information on Product Packaging please refer to [www.mornsun-power.com](http://www.mornsun-power.com), Packaging bag number: 58220306;
2. Unless otherwise specified, parameters in this datasheet were measured under the conditions of  $T_a=25^{\circ}\text{C}$ , humidity $<75\%RH$  with nominal input voltage and rated output load;
3. The room temperature derating of  $3.5^{\circ}\text{C}/1000\text{m}$  is needed for operating altitude greater than 2000m;
4. All index testing methods in this datasheet are based on our company corporate standards;
5. In order to improve the efficiency at high input voltage, there will be audible noise generated, but it does not affect product performance and reliability;
6. We can provide product customization service, please contact our technicians directly for specific information;
7. Products are related to laws and regulations: see "Features" and "EMC";
8. The out case needs to be connected to the earth (⊕) of system when the terminal equipment in operating;
9. The output voltage can be adjusted by the ADJ, clockwise to decrease;
10. Our products shall be classified according to ISO14001 and related environmental laws and regulations, and shall be handled by qualified units;
11. The power supply is considered a component which will be installed into a terminal equipment. All EMC tests should be confirmed with the final equipment. Please consult our FAE for EMC test operation instructions.

## Mornsun Guangzhou Science & Technology Co., Ltd.

Address: No. 8 Nanyun 4th Road, Huangpu District, Guangzhou, China

Tel: 86-20-38601850

Fax: 86-20-38601272

E-mail: [info@mornsun.cn](mailto:info@mornsun.cn)

[www.mornsun-power.com](http://www.mornsun-power.com)