

UNIT: mm (毫米)

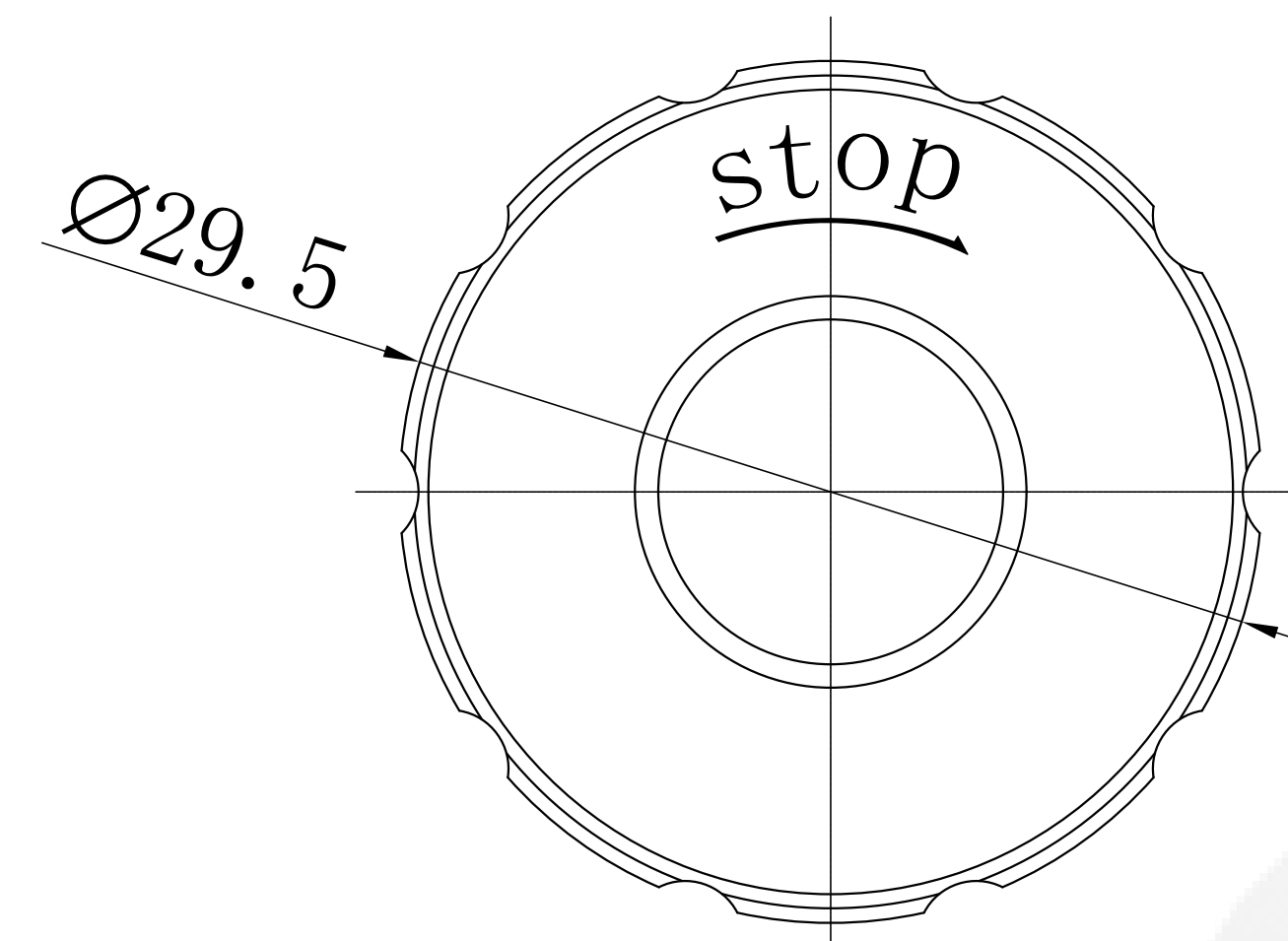

开关结构说明:
Switch structure description:

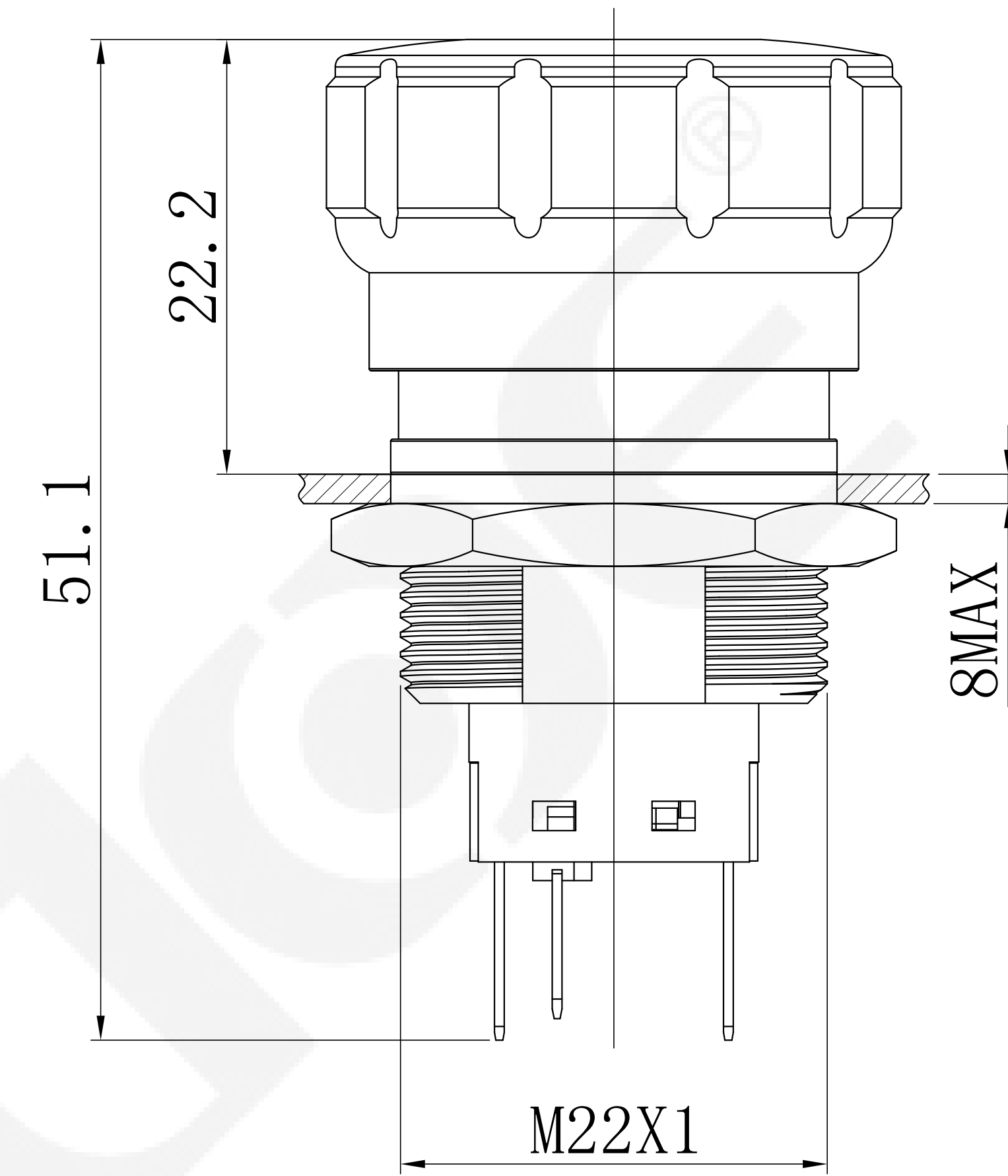
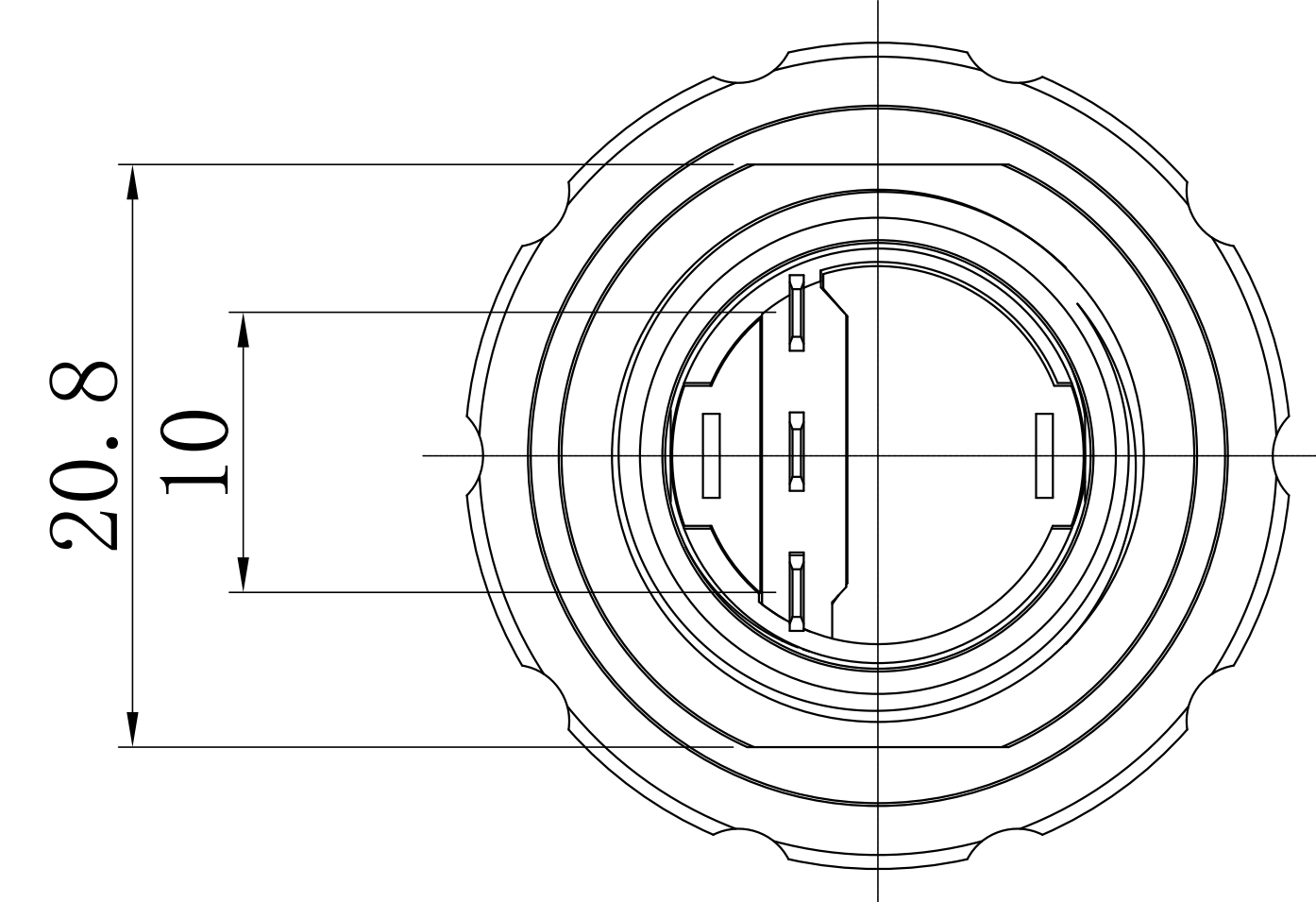
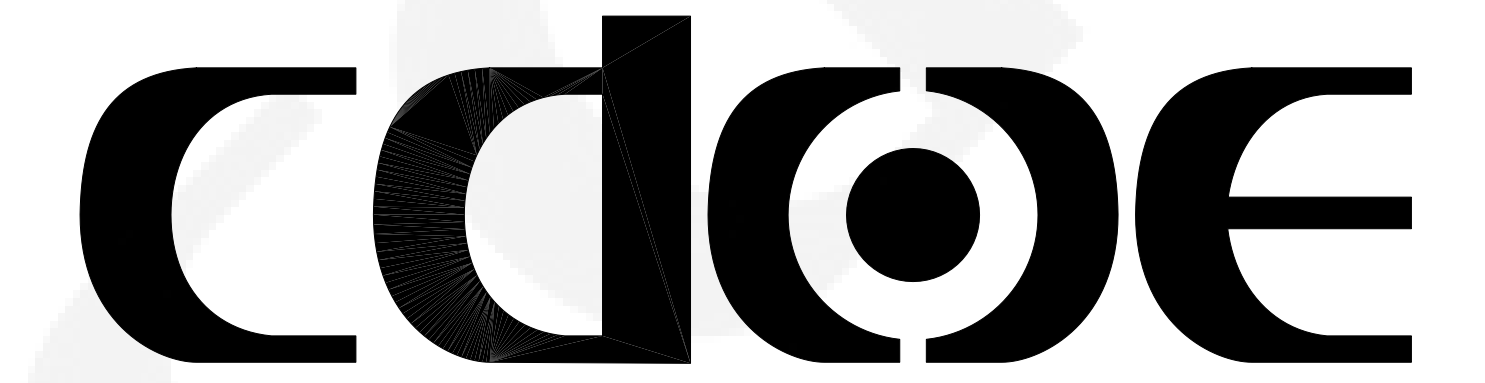
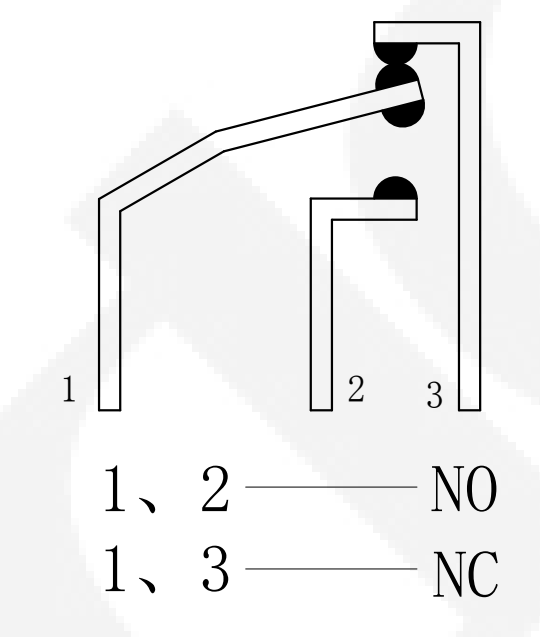

灯珠等效电路:
Lamp bead equivalent circuit:

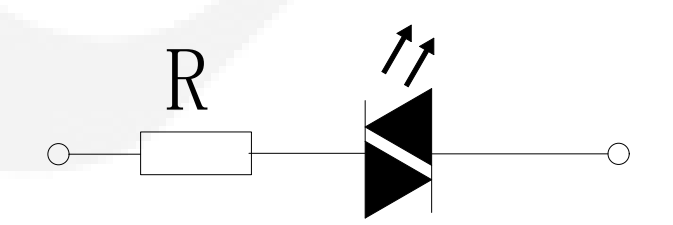

安装孔尺寸:
Mounting hole size:

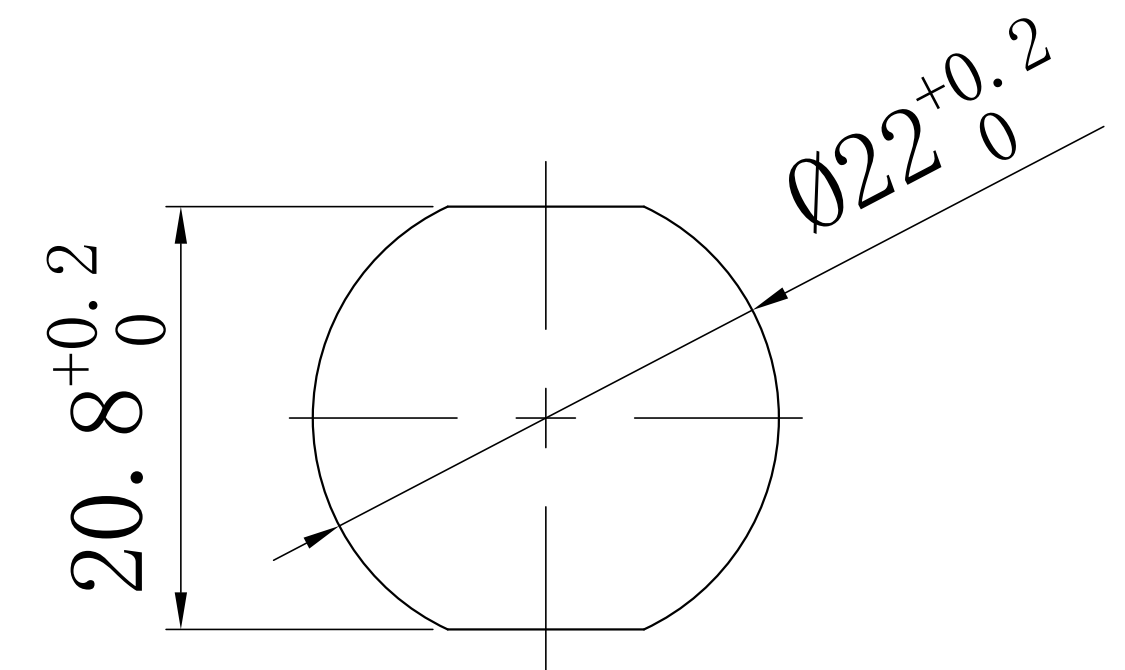

性能要求:
Performance requirements:

- 防护等级: IP67;
Protection grade: IP67;
- 接触电阻: $\leq 50m\Omega$;
Contact resistance: $\leq 50m\Omega$
- 绝缘电阻: $\geq 100M\Omega$;
The insulation resistance: $\geq 100M\Omega$
- 抗电强度: AC2500V, 1min, 无闪烁、击穿;
Electrical resistance: AC2500V, 1min, no flicker and breakdown;
- 寿命: 电气部分在额定负载下动作5万次无异常。
Life: Electrical part: operate 50,000 times under rated load without any abnormality.

技术要求:

Technical requirements:

- 表面光洁, 平整无毛刺;
The surface is smooth without burr;
- 参数/批次字迹清晰, 无错位;
Clear handwriting of parameters/batches without any dislocation;
- 电气参数: $I_{th}: 5A$ $U_i: 250V$;
Electric parameter: $5A$ $U_i: 250V$;
- 工作环境温度: $-25^{\circ}C \sim +65^{\circ}C$;
Working environment temperature: $-25^{\circ}C \sim +65^{\circ}C$;
- 动作形式: 自锁式;
Operation type: Latching ;
- 动作行程: 约3mm;
Movement stroke: about 3mm
- 连接形式: 配套接插件/焊接导线;
Connection form: Matching connectors/Welding wire;
- 拧紧力矩: 约0.6Nm;
Tightening torque: about 0.6Nm;
- 开关组合: 1NO1NC;
Contact configuration: 1NO1NC;
- 外观材料: 按键: 铝合金;
外壳: 不锈钢;
底座: PBT;
触点: 银合金;
Appearance material: Button surface: Aluminum alloy;
Housing: Stainless steel;
Pedestal: PBT;
Contact silver alloy
- 未标注公差按照GB/T 1804-m级。
Unmarked tolerance shall be in accordance with GB/T 1804-m class.

描 图
描 校
底 图 号
装 订 号

					YUEQING DAHE ELECTRIC CO., LTD.	
					乐清市大和电气有限公司	
					名称(TITLE):	
					M22 Metal emergency stop button switch	
					M22金属急停按钮开关	
					图号(DWG NO):	
					HBDS1-AGQ22F-11DTSC/J/R/S2	
标记	处数	更改文件号	签字	日期		
DR. 制图	APPD. 审核	SCALE. 比例	countersign. 会签	Date. 日期		
黄	陈秋霞	1:1		2023. 4. 18		
PW. 单重		P. 页码	第1页 共1页(1/1)			