

UNIT: mm (毫米)

cdoe

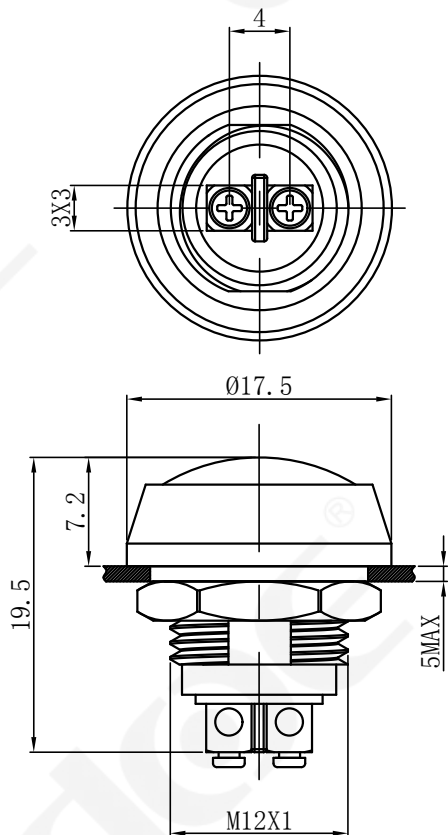

开关结构说明:
Switch structure description:

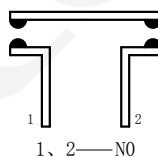

安装孔尺寸:
Mounting hole size:

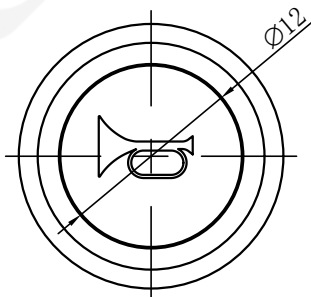
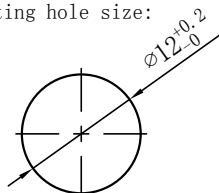

性能要求:

Performance requirements:

- 防护等级: IP65;
Protection grade: IP65;
- 接触电阻: $\leq 50\text{m}\Omega$;
Contact resistance: $\leq 50\text{m}\Omega$;
- 绝缘电阻: $\geq 100\text{M}\Omega$;
The insulation resistance: $\geq 100\text{M}\Omega$;
- 抗电强度: AC1500V, 1min, 无闪烁、击穿;
Electrical resistance: AC1500V, 1min, no flicker and breakdown;
- 寿命: 电气部分在额定负载下动作5万次无异常。
Life: Electrical part: operate 50,000 times under rated load without any abnormality.
机械部分: 动作100万次无异常;
Mechanical part: no abnormal movement for 100,000times

技术要求:

Technical requirements:

- 表面光洁, 平整无毛刺;
The surface is smooth without burr;
- 参数/批次字迹清晰, 无错位;
Clear handwriting of parameters/batches without any dislocation;
- 电气参数: $I_{th}: 3\text{A}$ $U_i: 250\text{V}$;
Electric parameter: 3A $U_i: 250\text{V}$;
- 工作环境温度: $-25^\circ\text{C} \sim +65^\circ\text{C}$;
Working environment temperature: $-25^\circ\text{C} \sim +65^\circ\text{C}$;
- 动作形式: 自复式;
Operation type: Momentary ;
- 动作行程: 约1.8mm;
Movement stroke: about 1.8mm;
- 连接形式: 配套接插件/焊接导线;
Connection form: Matching connectors/Welding wire;
- 拧紧力矩: 约0.4Nm;
Tightening torque: about 0.4Nm;
- 开关组合: 1NO;
Contact configuration: 1NO;
- 外观材料: 按键: PBT/UV;
外壳: 锌铝合金;
底座: PBT;
触点: 银合金;
Appearance material: Button surface: PBT/UV;
Housing: Zinc alloy;
Pedestal: PBT;
Contact silver alloy
- 未标注公差按照GB/T 1804-m级。
Unmarked tolerance shall be in accordance with GB/T 1804-m class.

描 图

描 校

底 图 号

装 订 号

					YUEQING DAHE ELECTRIC CO., LTD.	
					乐清市大和电气有限公司	
标记	处数	更改文件号	签字	日期	名称(TITLE): M12 Emergency stop button switch	
DR. 制图	APPD. 审核	SCALE. 比例	COUNTERSIGN. 会签	DATE. 日期	M12金属防水按钮开关	
黄	陈秋霞	2:1		2024.7.6	图号(DWG NO): HBDGQ12B-10/L/A/B/UV	
PW. 单重		P. 页码	第1页 共1页(1/1)			